

O. A. Plakhtii, Cand. Sc. (Tech.), Assoc. Prof.,
orcid.org/0000-0002-1535-8991,
V. P. Nerubatskyi, Cand. Sc. (Tech.), Assoc. Prof.,
orcid.org/0000-0002-4309-601X,
D. A. Hordiienko,
orcid.org/0000-0002-0347-5656,
H. A. Khoruzhevskyi,
orcid.org/0000-0003-2042-4938

Ukrainian State University of Railway Transport, Kharkiv,
Ukraine, e-mail: a.plakhtiy1989@gmail.com; NVP9@i.ua

CALCULATION OF STATIC AND DYNAMIC LOSSES IN POWER IGBT-TRANSISTORS BY POLYNOMIAL APPROXIMATION OF BASIC ENERGY CHARACTERISTICS

Purpose. Development of a calculation technique that allows the Matlab software to determine the static and dynamic losses in power IGBT-transistors and reverse diodes.

Methodology. Polynomial approximation of the energy dependences of IGBT-transistors using the least squares method. Simulation in Matlab/Simulink. Power loss calculation with MelcoSim 5.1.

Findings. The proposed calculation method allows the Matlab software to determine with sufficient accuracy the static and dynamic losses in power IGBT-transistors and reverse diodes for any type of semiconductor converter with any control law. The simulation confirms the accuracy of the proposed technique for calculating power losses in semiconductor converters. In addition, the presented method allows determining not only the power loss, but also the temperature of the power transistor to prevent it from failing. The results of the approximation of the characteristics of high-voltage power IGBT-transistors manufactured by Mitsubishi are presented.

Originality. The technique of simulation in Matlab/Simulink program for calculation of static and dynamic power losses in power IGBT-transistors, as well as power losses in reverse diodes is developed. The presented method allows determining power losses and efficiency in any semiconductor converter with any control algorithm, which is a very useful tool in research.

Practical value. The presented technique in Matlab simulation allows determining power losses and temperature of power transistors of any type in the composition of any semiconductor converter.

Keywords: *polynomial approximation, least-squares method, current-voltage characteristic, energy efficiency, static and dynamic losses*

Introduction. Power losses and efficiency are among the most important indicators in semiconductor power converters [1].

The “manual” calculation of power losses in semiconductor converters with different types of modulation is quite a challenge and requires a new method.

Literature review. Programs for automatic power losses calculation in power IGBT-transistors, such as MelcoSim, Semisel, Iposim, and others are quite common. These programs are quite convenient tool; however, they allow automatic power losses calculation only for “standard” topologies (boost and down DC voltage converter, three phase stand-alone voltage inverter) with “standard” control algorithms (pulse width modulation (PWM) with constant fill factor, sinusoidal PWM, space-vector PWM). The disadvantages of existing programs are the lack of ability to model “non-standard” topologies, such as power active filters, active rectifiers with power factor correction, multilevel converters and many other topologies, or standard topologies with non-standard control algorithms [2].

Matlab/Simulink is one of the most popular programs for the study of semiconductor converters, which allows simulat-

ing any converter topology with any control system virtually [3]. However, the disadvantage of this program is the lack of consideration of dynamic power losses in IGBT-transistors. In addition, the volt-ampere characteristic (VAC) of IGBT-transistors is presented as a linear function (Fig. 1).

In SPICE type modeling programs such as Multisim, LT-spice, TINA, MicroCap, the simulation of volt-ampere processes is more accurate [4]. Transistor models in SPICE modeling take into account the on and off times of transistors and take into account dynamic losses in transistors [5]. However, the above programs allow simulating extremely low-power transistors, as models of power high-voltage IGBT-transistors in these programs simply do not exist.

Research [6] presents the calculation of the power losses in the IGBT-transistor and the calculation temperature of the switch. However, this publication does not specify the characteristics of which particular transistor was considered in the calculation. In addition, it does not indicate how dynamic power losses are taken into account in this study.

In research [7, 8] there are given methods for modeling dynamic losses in IGBT-transistors. However, the presented method has certain disadvantages:

- the dependence of the E_{on} switching-on energy and the E_{off} switching-off energy of the emitter current in the IGBT-transistors

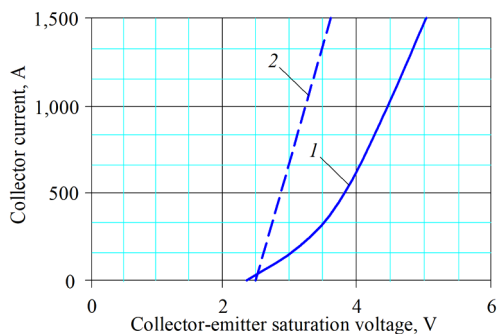

Fig. 1. Volt-ampere characteristic:
1 – real transistor; 2 – transistor in the Matlab/Simulink

are represented by linear dependencies, although in reality these characteristics have a parabolic appearance;

- absence of consideration of power losses in the reverse diode of the transistor.

Purpose. The purpose of the study is to develop a universal process of modeling static and dynamic losses in power semiconductor transistors, taking into account the influence of parallel diodes, which will allow determining the power losses for any types of semiconductor converters with any type of modulation. Confirmation of the versatility of the method is carried out by simulation in Matlab.

Calculations of static and dynamic losses in power IGBT-transistors. Determination of power losses in IGBT-transistors can be performed by calculating static P_{DC} and dynamic P_{SW} losses in IGBT-transistors VT and parallel VD diodes according to the expressions [9, 10]

$$\Delta P = P_{VT} + P_{VD};$$

$$P_{VT} = P_{VT.DC} + P_{VT.SW};$$

$$P_{VD} = P_{VD.DC} + P_{VD.SW};$$

where $P_{VT.DC}$ is the static losses in IGBT-transistors; $P_{VT.SW}$ is the dynamic losses in IGBT-transistors; $P_{VD.DC}$ is the static losses in parallel diodes; $P_{VD.SW}$ is the dynamic losses in parallel diodes.

Static losses in IGBT-transistors P_{DC} are determined according to the expression

$$P_{DC} = \frac{1}{2\pi} \cdot \int_0^{\pi} (I_c \cdot V_{ce}(I_c) \cdot D_{on}) \cdot dt,$$

where I_c is the collector current; $V_{ce}(I_c)$ is the voltage between the collector and the emitter, which depends on the value of the collector current; D_{on} is the coefficient filling PWM.

Dynamic losses in IGBT-transistors P_{SW} are determined to the expression

$$P_{SW} = \frac{1}{2\pi} \int_0^{\pi} [(E_{on}(I_c) + E_{off}(I_c) \cdot f)] \cdot dt,$$

where f is the frequency PWM; $E_{on}(I_c)$ is the energy dissipated in the transistor at startup, which depends on the value of the collector current; $E_{off}(I_c)$ is the energy dissipated in the transistor at switch-off, which depends on the value of the collector current.

Power losses in reverse diode of the power transistor include conductivity losses and losses associated with losses of power for recovery [11]. The calculation of the power losses in the reverse diode is carried out according to the expressions

$$P_{VD} = P_{DC.VD} + P_{SW};$$

$$P_{SW} = E_{rec} \cdot f;$$

$$P_{DC.VD} = U_{fwd} \cdot I.$$

Energy characteristics of IGBT-transistors. In determining the power losses of IGBT-transistors, the following dependencies are basic [12]:

- dependence of the voltage between the collector and the emitter from the collector current (VAC of the transistor);
- VAC of the reverse diode;
- the dependence of the power of the transistor, the power of the transistor, as well as the energy of restoring the reverse diode from the emitter current of the transistor.

The energy characteristics of the IGBT-transistor type CM750HG-130R are shown in Fig. 2.

It is worth noting that the energy characteristics of the transistor at temperatures of 25 and 125 °C are quite different and with increasing temperature the losses in the transistor increase.

Presented in Fig. 2 datasheet 1 transistor energy dependencies are shown in Table 1.

Approximation and interpolation of the energy characteristics of an IGBT-transistor type CM1200HG-90R. If there is an error in the table data output (transmitted “by eye”), it is inappropriate to use the interpolation method for their analysis and to find an approximate function that exactly passes through all points of the original table function. In this case resort to the construction of an approximating function, which runs close to the given points, and closest to the starting points. The approximation smoothes out the processed experimental data containing the deviation, i.e. it is a way of finding intermediate values of a value by a discrete set of known values [13].

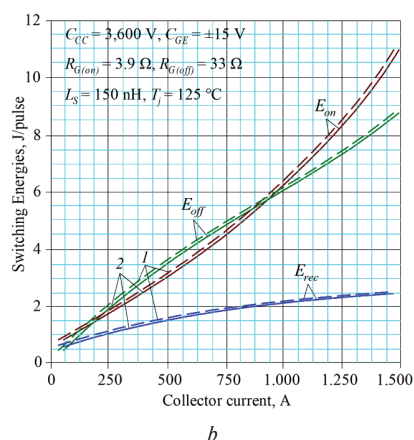
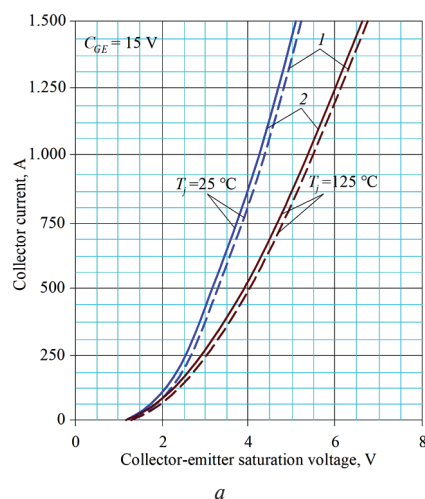

Fig. 2. The energy characteristics of the IGBT-transistor type CM750HG-130R:

a – VAC of the transistor $V_{ce}(I)$; b – dependences of the energy of switching on, off and restoring the reverse diode from the current; 1 – datasheet; 2 – after the approximation

Table 1

Energy characteristics of CM1200HG-90R type transistor from collector current at temperature of 125 °C

Collector current, kA	Switch-on energy, E_{on} J/pulse	Switch-off energy, E_{off} J/pulse	Restoring energy, E_{rec} J/pulse	VAC of the transistor, $V_{ce}(I_{ce})$ V	VAC of the diode, V
0.0	0.31	0.32	0.5	1.0	0.7
0.1	0.75	0.8	0.7	1.65	1.02
0.2	1.1	1.15	0.9	2.15	1.36
0.3	1.45	1.5	1.1	2.5	1.6
0.4	2.0	1.95	1.25	2.75	1.76
0.5	2.4	2.25	1.5	3.0	1.9
0.6	2.75	2.5	1.7	3.2	2.04
0.7	3.125	2.75	1.9	3.4	2.2
0.8	3.65	3.1	2.0	3.65	2.32
0.9	4.0	3.4	2.15	3.825	2.44
1.0	4.5	3.725	2.25	4.05	2.58
1.1	5.0	4.0	2.35	4.2	2.66
1.2	5.5	4.25	2.45	4.4	2.8
1.3	6.0	4.55	2.5	4.55	2.9
1.4	6.5	4.85	2.55	4.75	3.0
1.5	7.05	5.1	2.6	4.9	3.1
1.6	7.75	5.45	2.65	5.05	3.2
1.7	8.3	5.7	2.65	5.2	3.3
1.8	9.0	6.0	2.65	5.375	3.4
1.9	9.75	6.25	2.65	5.6	3.5
2.0	10.45	6.6	2.65	5.7	3.6

The main task of interpolation is to replace a tabularly given function with a simple analytic function and then find with it the approximate values at those points inside the interval where the initial function is not specified.

There are different types of approximations: linear, partially linear, static, exponential, and polynomial [14]. In addition, there are various mathematical methods that allow for approximation. The purpose of the approximation is to determine the mathematical functions that most accurately describe the obtained table dependencies $E_{on}(I)$, $E_{off}(I)$, $E_{rec}(I)$, $V_{ce}(I)$, $V_{VD}(I)$.

For automated calculation of power losses in power IGBT switches, the VAC of the transistor and the dependence of the switching-on energy and the switching-off energy on the load current were approximated by the least squares method [15]. The mathematical approximation process was performed in the Wolfram Mathematica program.

If we remove the requirement of the approximating function passing through nodes and replace the requirement of the minimum of the sum of squares of the difference between the values of the approximating function and the function approximating at nodes, then the least squares method will be obtained, which does not ignore the errors in the values of the approximating function and tries to average their impact on the result of the approximation [16].

The least-squares method is based on minimizing the functional [17]

$$F = \sum_{i=0}^n (\varphi(x_i) - y_i)^2 \rightarrow \text{Min},$$

where n is the number of measurement points.

In this method, the approximating function $f(x)$ is a polynomial of degree k

$$\varphi(x) = a_0 + a_1 \cdot x + \dots + a_k \cdot x^k,$$

or with by the substitution

$$F = \sum_{i=0}^n (a_0 + a_1 \cdot x + \dots + a_k \cdot x^k - y_i)^2 \rightarrow \text{Min}.$$

To find unknown coefficients, we find derivatives of the functional by the corresponding factor and equate to zero

$$\begin{cases} \frac{\partial F}{\partial a_0} = 2 \cdot \sum_{i=0}^n (a_0 + a_1 \cdot x + \dots + a_k \cdot x^k - y_i) = 0 \\ \frac{\partial F}{\partial a_1} = 2 \cdot \sum_{i=0}^n x_i \cdot (a_0 + a_1 \cdot x + \dots + a_k \cdot x^k - y_i) = 0 \\ \vdots \\ \frac{\partial F}{\partial a_k} = 2 \cdot \sum_{i=0}^n x_i^k \cdot (a_0 + a_1 \cdot x + \dots + a_k \cdot x^k - y_i) = 0 \end{cases}$$

After the transformations, we obtain a system of equations

$$\begin{cases} n + \sum_{i=0}^n x_i + \dots + \sum_{i=0}^n x_i^k = \sum_{i=0}^n y_i \\ \sum_{i=0}^n x_i + \sum_{i=0}^n x_i^2 + \dots + \sum_{i=0}^n x_i^{k+1} = \sum_{i=0}^n x_i \cdot y_i \\ \vdots \\ \sum_{i=0}^n x_i^k + \sum_{i=0}^n x_i^{k+1} + \dots + \sum_{i=0}^n x_i^{2k} = \sum_{i=0}^n x_i^k \cdot y_i \end{cases}$$

Solving the obtained system of equations, we can find the coefficients a_0, a_1, \dots, a_k of polynomial functions to describe the energy characteristics of each particular power transistor. The energy performance approximation was performed automatically using Wolfram Mathematica.

The results of the approximation of the energy characteristics of the high-voltage power IGBT-transistor manufactured by Mitsubishi are shown in Table 2. For the convenience of describing the coefficients in the approximate dependence functions, the current is given in kilo amperes.

The approximation results are consistent with the output characteristics of the CM750HG-130R type IGBT-transistor. The mathematical dependencies obtained almost perfectly describe the output dependencies of the datasheet transistor (Fig. 2).

The advantage of polynomial approximation is a fairly accurate description of the tabular data in the specified range. However, outside the table range, the resulting function may behave indefinitely.

When the current is exceeded through the transistor above the permissible values, its physical destruction occurs [18]. Graphically this effect is shown in Fig. 3.

Thus, the polynomial approximation allows for fairly exact mathematical description of the power dependences of the power transistors in a given range, but outside this range the function behaves incorrectly, which imposes restrictions on the application of this method, namely, the loss calculation works correctly only in a given current limitation range.

Development of a simulation model for calculating losses in an IGBT-transistor. The output signals for determining static and dynamic power losses in Matlab are the transistor control signal and the transistor current signal.

The definition of static losses is defined as an integral of instantaneous power to the expression [19]

$$P_{stat} = \int I_c \cdot V_{ce}(I_c) dt.$$

An example of creating a simulation model for calculating losses in an IGBT-transistor type CM800HC-66H is shown in Fig. 4.

Results of polynomial approximation of energy characteristics of power IGBT-transistors of different classes

Transistor	Results of approximation
CM750HG-130R 6600 B, 750 A	$U_{ce}(I) = 2.3774 \cdot I^5 - 10.499 \cdot I^4 + 17.946 \cdot I^3 - 15.401 \cdot I^2 + 9.7617 \cdot I + 1.3188$ $U_{VD}(I) = 2.4376 \cdot I^5 - 10.013 \cdot I^4 + 15.671 \cdot I^3 - 12.144 \cdot I^2 + 7.2184 \cdot I + 0.7822$ $E_{rec}(I) = 0.0101 \cdot I^4 + 0.1402 \cdot I^3 - 1.0272 \cdot I^2 + 2.4108 \cdot I + 0.4976$ $E_{on}(I) = 0.1699 \cdot I^4 + 0.5074 \cdot I^3 + 0.4161 \cdot I^2 + 4.577 \cdot I + 0.5697$ $E_{off}(I) = 0.0139 \cdot I^4 + 1.2829 \cdot I^3 - 3.7047 \cdot I^2 + 8.4595 \cdot I - 0.0041$
CM1200HG-90R 4500 B, 1200 A	$U_{ce}(I) = 0.7622 \cdot I^5 - 4.4108 \cdot I^4 + 9.6859 \cdot I^3 - 10.245 \cdot I^2 + 7.1998 \cdot I + 1.0169$ $U_{VD}(I) = 0.33 \cdot I^5 - 1.9618 \cdot I^4 + 4.4951 \cdot I^3 - 5.1124 \cdot I^2 + 4.1169 \cdot I + 0.6899$ $E_{rec}(I) = 0.2203 \cdot I^4 - 0.9136 \cdot I^3 + 0.513 \cdot I^2 + 1.9475 \cdot I + 0.4954$ $E_{on}(I) = 0.0367 \cdot I^4 + 0.2901 \cdot I^3 - 0.2417 \cdot I^2 + 4.1088 \cdot I + 0.3115$ $E_{off}(I) = -0.1981 \cdot I^4 + 1.0595 \cdot I^3 - 2.0282 \cdot I^2 + 4.5203 \cdot I + 0.3366$
CM800HC-66H 3300 B, 800A	$U_{ce}(I) = -6.085 \cdot I^6 + 31.869 \cdot I^5 - 65.313 \cdot I^4 + 66.621 \cdot I^3 - 35.955 \cdot I^2 + 12 \cdot I + 0.6258$ $U_{VD}(I) = 0.6245 \cdot I^3 - 2.1404 \cdot I^2 + 3.7624 \cdot I + 0.76$ $E_{rec}(I) = -0.5676 \cdot I^2 + 2.269 \cdot I + 0.9238$ $E_{on}(I) = 0.001201 \cdot I + 0.121$ $E_{off}(I) = 0.4111 \cdot I^3 - 1.1164 \cdot I^2 + 1.677 \cdot I + 0.2012$
CM1200HB-50H 2500 B, 1200 A	$U_{ce}(I) = 0.0586 \cdot I^4 - 0.3132 \cdot I^3 + 0.2529 \cdot I^2 + 1.6165 \cdot I + 1.2544$ $U_{VD}(I) = -0.001 \cdot I^3 - 0.2254 \cdot I^2 + 1.5294 \cdot I + 0.8259$ $E_{rec}(I) = -0.1089 \cdot I^2 + 0.3528 \cdot I + 0.2666$ $E_{on}(I) = -0.0182 \cdot I^3 + 0.1893 \cdot I^2 + 0.5797 \cdot I + 0.1952$ $E_{off}(I) = -0.017 \cdot I^3 - 0.1293 \cdot I^2 + 1.0389 \cdot I + 0.2487$
CM1200DC-34S 1700 B, 1200 A	$U_{ce}(I) = -0.1623 \cdot I^4 + 0.9421 \cdot I^3 - 2.0092 \cdot I^2 + 2.7468 \cdot I + 0.5729$ $U_{VD}(I) = -0.1856 \cdot I^4 + 1.0545 \cdot I^3 - 2.1711 \cdot I^2 + 2.7352 \cdot I + 0.6813$ $E_{rec}(I) = 0.0054 \cdot I^5 - 0.0368 \cdot I^4 + 0.1002 \cdot I^3 - 0.1601 \cdot I^2 + 0.2309 \cdot I + 0.0227$ $E_{on}(I) = 0.2406 \cdot I^2 - 0.006 \cdot I + 0.0496$ $E_{off}(I) = 0.0587 \cdot I^2 + 0.1842 \cdot I + 0.0547$

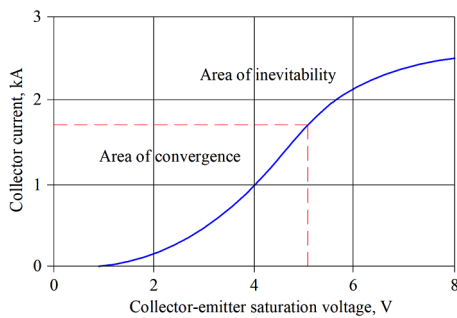

Fig. 3. Area of convergence and inevitability $V_{ce}(I_c)$ IGBT-transistor

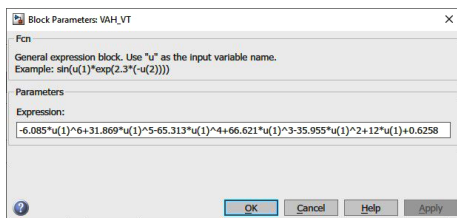
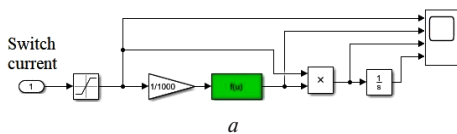

Fig. 4. A sub-model of static losses calculation IGBT-transistor: a – type of model; b – given approximate dependence of voltage on current

Mathematically, the dependence $V_{ce}(I_c)$ is introduced into the block “Fcn”, which makes it possible to set the obtained approximate dependence [20].

The results of static losses simulation are shown in Fig. 5.

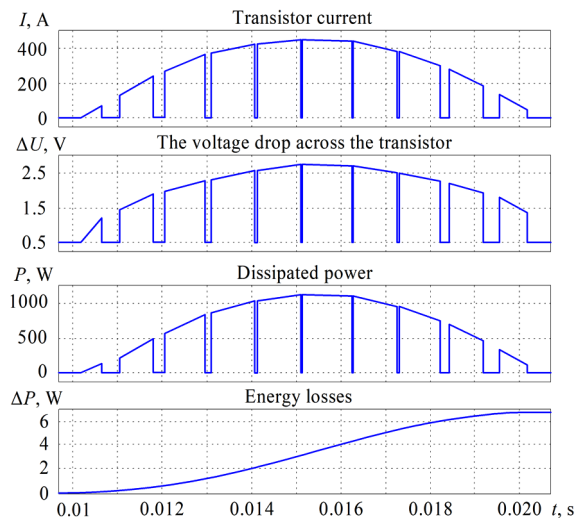

Fig. 5. Static losses simulation results

Dynamic losses calculation is more complicated. A simulation model for the calculation of dynamic losses in a power transistor is shown in Fig. 6.

The results of dynamic losses simulation are shown in Fig. 7.

As can be seen from Fig. 7, the on and off energies depend on the magnitude of the transistor current. Dynamic losses modeling requires the task of a simulation method with a constant calculation step.

Verification of the developed models and analysis of the convergence of the potential distribution of Matlab with MelcoSim. Verification of the developed technique for determining power loss in power IGBT-transistors has been carried out. A comparative calculation of the power losses made using the MelcoSim 5.1 program for a three-level standalone voltage inverter with RL load (Fig. 8), as well as the calculation of the power losses, performed in Matlab using the described procedure methods.

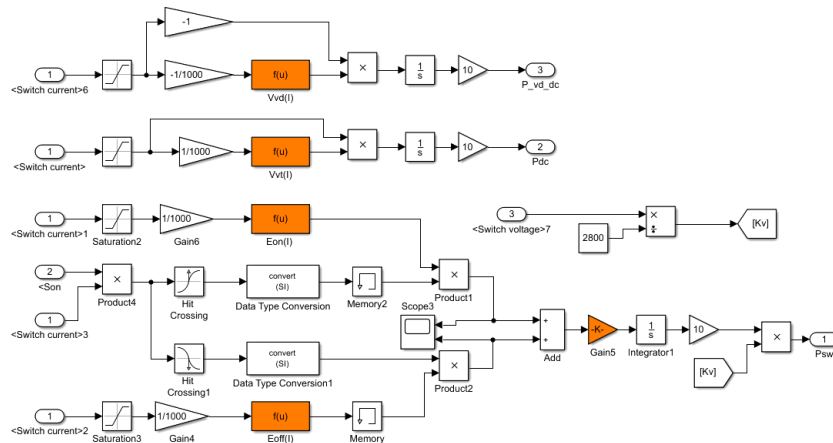

Fig. 6. Simulation model of power losses calculation in IGBT module with reverse diode

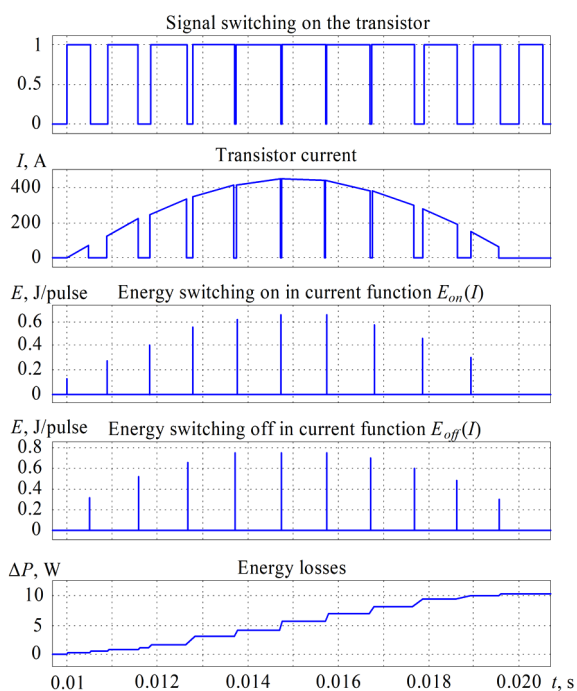

Fig. 7. The results of dynamic losses simulation

Initial calculation data are: circuit of three-phase stand-alone voltage inverter; voltage in the DC circuit 2800 V; PWM frequency 2 kHz; average square output current 934.5 A; active load resistance of 1 Ohm; load inductance of 1 mH, $\cos \varphi = 0.954$.

An analysis of the convergence of the calculation results in the Matlab and MelcoSim programs is given in Table 3.

Several studies have shown that the discrepancy between the calculation of power losses in the developed Matlab model and the calculation performed by the specialized program MelcoSim 5.1 does not exceed 2.1 %.

Table 3 shows the deviation of the calculation results in the MelcoSim program, the disadvantage of which is that the program in autonomous inverters calculates pure-sinusoidal current switching without distortion, that is, takes the value of the current during the switching based on the sinusoidal function. For low-key switches with a low switching frequency, the shape of the load current can be significantly different from a sine wave, resulting in distorted calculation results.

The perfect and real form of inverter output current (RMS 140 A) is shown in Fig. 9.

As can be seen from Fig. 9, the shape of the real output current of the inverter is significantly different from the ideal sinusoidal shape at the moments of switching.

Conclusions. The proposed calculation method allows the Matlab software to determine with sufficient accuracy the static and dynamic losses in power IGBT-transistors for any type of

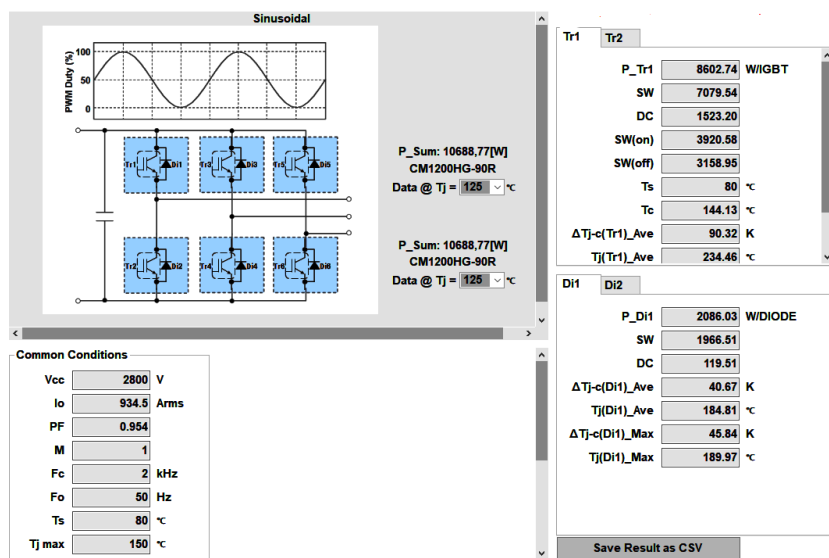

Fig. 8. Program interface MelcoSim 5.1

Table 3

The results of the calculation of power losses in a single IGBT-transistor type CM1200HG-90R

Parameter	Calculation in Matlab, W	Calculation in Melcosim, W	Relative calculation error, %
Dynamic losses in transistor, W	7079.54	7094.94	0.217
Static losses in the transistor, W	1523.20	1519.14	0.266
Dynamic losses in the reverse diode, W	1966.51	2005.68	-1.992
Static losses in the reverse diode, W	119.51	121.93	-2.024
Total power losses, W	10 688.77	10 771.96	0.778

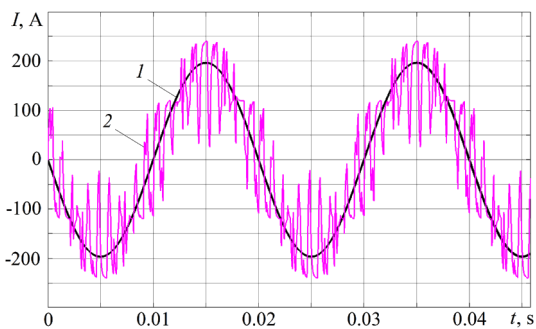

Fig. 9. The perfect (1) and real (2) form of inverter output current

semiconductor converter with any control law. The technique consists in the polynomial interpolation of the energy characteristics of IGBT-transistors by the least squares method.

References.

1. Blahnik, V., & Talla, J. (2016). Single-phase synchronization for traction active rectifier. *International Conference on Applied Electronics (AE)*, 23-26. <https://doi.org/10.1109/ae.2016.7577233>.
2. Nerubatskiy, V., Plakhtii, O., & Kotlyarov, V. (2019). Analysis of topologies of active four-quadrant rectifiers for implementing the INDUSTRY 4.0 principles in traffic power supply systems. *International scientific journal "INDUSTRY 4.0"*, 4(3), 106-109.
3. Plakhtii, O., Nerubatskiy, V., Ryshchenko, I., Zinchenko, O., Tykhonravov, S., & Hordiienko, D. (2019). Determining additional power losses in the electricity supply systems due to current's higher harmonics. *Eastern-European Journal of Enterprise Technologies*, 1(8(97)), 6-13. <https://doi.org/10.15587/1729-4061.2019.155672>.
4. Bouzida, A., Abdelli, R., & Ouadah, M. (2016). Calculation of IGBT power losses and junction temperature in inverter drive. *8th International Conference on Modelling, Identification and Control (ICMIC)*, 768-773. <https://doi.org/10.1109/icmic.2016.7804216>.
5. Gervasio, F., Mastromauro, R., & Liserre, M. (2015). Power losses analysis of two-levels and three-levels PWM inverters handling reactive power. *IEEE International Conference on Industrial Technology (ICIT)*, 1123-1128. <https://doi.org/10.1109/icit.2015.7125248>.
6. Pillay, T., & Saha, A. (2017). Analysis and simulation of flying capacitor multilevel inverter using PDPWM strategy. *International Conference on Innovative Mechanisms for Industry Applications (ICIMIA)*, 1061-1070.
7. Shcherbak, Ya. V., Plakhtii, O. A., & Nerubatskiy, V. P. (2017). Regulatory characteristics of the active quadrature con-

verter in regimens and recuperation modes. *Technical electrodynamics*, 6, 26-31. <https://doi.org/10.15407/techned2017.06.026>.

8. Ahmadzadeh, T., Sabahi, M., & Babaei, M. (2017). Modified PWM control method for neutral point clamped multilevel inverters. *14th International Conference on Electrical Engineering/Electronics, Computer, Telecommunications and Information Technology (ECTI-CON)*, 765-768.
9. Dai, P., Guoand, G., & Gong, Z. (2016). A Selection Pre-charge Method for Modular Multilevel Converter. *International Journal of Control and Automation*, 9(4), 161-170.
10. Plakhtii, O. A., & Nerubatskiy, V. P. (2018). Analyses of energy efficiency of interleaving in active voltage-source rectifier. *2018 IEEE 3rd International Conference on Intelligent Energy and Power Systems (IEPS)*, 253-258. <https://doi.org/10.1109/IEPS.2018.8559514>.
11. Zhao, G. I., Wang, L., Li, Q., & Chen, G. (2014). Analyze and compare the efficiency of two-level and three-level inverter in SVPWM. *9th IEEE Conference on Industrial Electronics and Applications*, 1954-1958. <https://doi.org/10.1109/iciea.2014.6931488>.
12. Vasil'ev, B. Yu. (2015). Providing overmodulation mode and increasing energy conversion efficiency in autonomous power inverters of electric drives. *Electricity*, 6, 47-55.
13. Rodder, S., Biswas, M., & Khan, Z. (2016). A modified PWM technique to improve total harmonic distortion of multilevel inverter. *9th International Conference on Electrical and Computer Engineering (ICECE)*, 46-54. <https://doi.org/10.1109/ICECE.2016.7853970>.
14. Fomin, O. (2014). Modern requirements to carrying systems of railway general-purpose gondola cars. *Scientific and technical journal "Metallurgical and Mining Industry"*, 5, 31-43.
15. Gevorkyan, E. S., Rucki, M., Kagramanyan, A. A., & Nerubatskiy, V. P. (2019). Composite material for instrumental applications based on micro powder Al₂O₃ with additives nano-powder SiC. *International Journal of Refractory Metals and Hard Materials*, (82), 336-339. <https://doi.org/10.1016/j.jirm-hm.2019.05.010>.
16. Plakhtii, O. A., Nerubatskiy, V. P., Hordiienko, D. A., & Tsybulnyk, V. R. (2019). Analysis of the energy efficiency of a two-level voltage source inverter in the overmodulation mode. *Naukovyi Visnyk Natsionalnoho Hirnychoho Universytetu*, (4), 68-72. <https://doi.org/10.29202/nvngu/2019-4/9>.
17. Ferdowski, F., Yazdankhah, A., & Rohani, H. (2014). A combinative method to control output power fluctuations of large gridconnected photovoltaic systems. *In Environment and Electrical Engineering (EEEIC)*, 260-264.
18. Dias, R. A., Lira, G. R., Costa, E. G., Ferreira, R. S., & Andrade, A. F. (2018). Skin effect comparative analysis in electric cables using computational simulations. *2018 Simposio Brasileiro de Sistemas Eletricos (SBSE)*, 1-6. <https://doi.org/10.1109/SBSE.2018.8395687>.
19. Ferdowski, F., Edrington, C., & Elmezyani, T. (2015). Real-time stability assessment utilizing non-linear time series analysis. *In North American Power Symposium (NAPS)*, 1-6.
20. Arcega, F. J., & Pardina, A. (2014). Study of harmonics-thermal effect in conductors produced by skin effect. *IEEE Latin America Transactions*, 12(8), 1488-1495. <https://doi.org/10.1109/TLA.2014.7014518>.

Розрахунок статичних і динамічних втрат у силових IGBT-транзисторах шляхом поліноміальної апроксимації базових енергетичних характеристик

О. А. Плахтій, В. П. Нерубацький, Д. А. Гордієнко, Г. А. Хоружевський

Український державний університет залізничного транспорту, м. Харків, Україна, e-mail: a.plakhtiy1989@gmail.com; NVP9@i.ua

Мета. Розробка методики розрахунку, що дозволяє у програмному пакеті Matlab визначати статичні й динамічні втрати в силових IGBT-транзисторах та зворотних діодах.

Методика. Поліноміальна апроксимації енергетичних залежностей IGBT-транзисторів методом найменших квадратів. Моделювання у програмі Matlab/Simulink. Розрахунок втрат потужності за допомогою програми MelcoSim 5.1.

Результати. Запропонована методика розрахунку дозволяє у програмному пакеті Matlab із досить високою точністю визначати статичні й динамічні втрати в силових IGBT-транзисторах і зворотніх діодах для будь-якого типу напівпровідникового перетворювача з будь-яким законом керування. Імітаційне моделювання підтверджує точність запропонованої методики розрахунку втрат потужності в напівпровідникових перетворювачах. Крім того, представлена методика дозволяє визначити не тільки втрати потужності, але й температуру силового транзистора для запобігання виходу його з ладу. Представлені результати апроксимації характеристик високовольтних силових IGBT-транзисторів виробництва компанії Mitsubishi.

Наукова новизна. Розроблена методика імітаційного моделювання у програмі Matlab/Simulink розрахунку статичних й динамічних втрат потужності в силових IGBT-транзисторах, а також втрат потужності у зворотних діодах. Представлена методика дозволяє визначити втрати потужності та ККД у будь-якому напівпровідниковому перетворювачі з будь-яким алгоритмом керування, що є досить корисним інструментом у дослідженнях.

Практична значимість. Представлена методика в імітаційному моделюванні Matlab дозволяє визначити втрати потужності й температуру силових транзисторів будь-яких типів у складі будь-якого напівпровідникового перетворювача.

Ключові слова: *поліноміальна апроксимація, метод найменших квадратів, вольт-амперна характеристика, енергоефективність, статичні й динамічні втрати*

Расчёт статических и динамических потерь в силовых IGBT-транзисторах путём полиномиальной аппроксимации базовых энергетических характеристик

А. А. Плахтий, В. П. Нерубацкий, Д. А. Гордиенко, Г. А. Хоружевский

Украинский государственный университет железнодорожного транспорта, г. Харьков, Украина, e-mail: a.plakhtiy1989@gmail.com; NVP9@i.ua

Цель. Разработка методики расчёта, которая позволяет в программном пакете Matlab определять статические и динамические потери в силовых IGBT-транзисторах и обратных диодах.

Методика. Полиномиальная аппроксимация энергетических зависимостей IGBT-транзисторов методом наименьших квадратов. Моделирование в программе Matlab/Simulink. Расчёт потерь мощности с помощью программы MelcoSim 5.1.

Результаты. Предложенная методика расчёта позволяет в программном пакете Matlab с достаточно высокой точностью определять статические и динамические потери в силовых IGBT-транзисторах и обратных диодах для любого типа полупроводникового преобразователя с любым законом управления. Имитационное моделирование подтверждает точность предложенной методики расчета потерь мощности в полупроводниковых преобразователях. Кроме того, представленная методика позволяет определить не только потери мощности, но и температуру силового транзистора для предотвращения выхода его из строя. Представлены результаты аппроксимации характеристик высоковольтных силовых IGBT-транзисторов производства компании Mitsubishi.

Научная новизна. Разработана методика имитационного моделирования в программе Matlab/Simulink расчёта статических и динамических потерь мощности в силовых IGBT-транзисторах, а также потерь мощности в обратных диодах. Представленная методика позволяет определить потери мощности и КПД в любом полупроводниковом преобразователе с любым алгоритмом управления, является весьма полезным инструментом в исследованиях.

Практическая значимость. Представленная методика в имитационном моделировании Matlab позволяет определить потери мощности и температуру силовых транзисторов любых типов в составе любого полупроводникового преобразователя.

Ключевые слова: *поліноміальна апроксимація, метод найменших квадратів, вольт-амперная характеристика, енергоефективність, статические и динамические потери*

Recommended for publication by O. S. Krasheninina, Doctor of Technical Sciences. The manuscript was submitted 24.05.19.